

DOMESTIC ROLL-UP DOOR OPERATOR INSTALLATION MANUAL

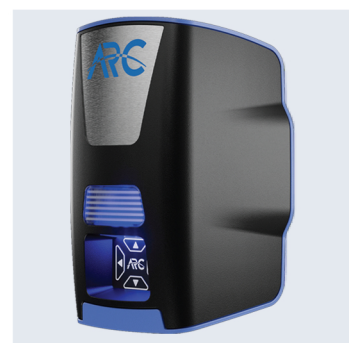

ARC

The image features the letters 'ARC' in a bold, dark blue, sans-serif font. A white, curved swoosh or underline passes through the middle of the letters, starting from the left side of the 'A', curving upwards and then downwards to the right, ending at the right side of the 'C'. The swoosh is positioned such that it appears to be layered on top of the letters.

Contents

	Page
1. Product Specifications _____	4
2. Safety notes _____	5
3. Pre-installation checks _____	5
4. Installation checks _____	5
5. Post-installation checks _____	6
6. Components of the Control Box _____	6
7. Controller card and connections _____	6
8. Electrical Installation _____	7
9. Installation check lists _____	7 - 8
10. Motor Orientation set-up _____	8
11. Programming menu and selector key _____	9 - 10
12. Beam Installation _____	11
13. Warranty and further information _____	11
14. General Faults and Recommendations _____	12
15. Quick reference diagram - Programming _____	13
16. Quick reference - Errors and Warnings _____	14

For any assistance with this product that is not covered in this manual please contact us at: 0860 326 666 (RSA)
or via our online support facility at www.arcsys.co.za

1. PRODUCT SPECIFICATIONS

Primary power supply to control box	220 – 240Vac @ 50Hz – 60Hz
Peak power consumption at control box	60W
Electrical class	Class 1
Motor voltage	24Vdc
Ancillary devices' power supply output	24Vdc @ 200mA
Built-in battery charger	Yes - 150mA intelligent charger, with low battery cut out
Motor current	Current limited to 6A
Rated Load	60N
Anti-crushing safety sensing	Yes – Electronic profiling
Number of operations on battery reserve	<p>25 - using the standard 1.3Ah batteries within 24hrs</p> <p>NB! Battery charging is optimised for 1.3Ah lead acid batteries.</p> <p>The number of operations on battery reserve depends on:</p> <ol style="list-style-type: none"> 1. Battery health 2. Battery charge level at the time of power failure <p>NB! Calculated on a 2.1m door travel with a movement resistance of 40N or less.</p>
Operating speed	<p>Up to 7m/min (Door with a drum diameter of 200mm)</p> <p>NB! Operating speed depends on door load and power supply.</p>
Built-in courtesy light	LED cluster
Courtesy light brightness	80 lumens
Courtesy light power	0.5W
Receiver frequency	433.92MHz
Receiver channels	4CH (Button trigger)
Receiver memory capacity	31 users
All users can be allowed control of all channels	Yes
Auto-close mode	Simple auto-close
Programming interface	Five button touch
Ingress protection (IP Rating)	IP20
Operating temperature range	-20 to 50° C (14F to 122F)

* Due to our ongoing innovation, technical specifications are subject to change without prior notice.

2. SAFETY NOTES

INSTALLERS AND USERS OF THE ARC UNIT MUST ADHERE TO THESE SAFETY REQUIREMENTS.

- Do not modify the ARC in any way, or substitute any of its parts.
- If any parts are substituted or altered, the correct and safe operation of the ARC cannot be guaranteed.
- Do not extend the cabling or replace the plug of the power cable supplied with the unit.
- Only suitably qualified installers may install, repair or service the ARC. Workmanship remains the responsibility of the installer.
- Disconnect the ARC unit and door from the mains before any electrical work, maintenance or repairs are done on the battery or door motor.
- Door and ARC unit replacement must only be performed by suitably qualified installers.
- Attend to system faults and repairs immediately. Continued use of the door or ARC before an installer can attend to it, is dangerous.
- The ARC may not be installed on a wicket door (where the wicket door is a smaller door within the main door).
- Be sure to insist on supervision when minors/persons lacking the required physical or mental capacity operate the door.
- Only operate the door when you have a clear sight of the door and its movement path.
- Ensure people and pets stay clear of the movement path of the door - and always keep this area clear of any obstacles.
- Unauthorised persons should not be allowed to tamper or play with door controls or emergency equipment.

NB! The ARC was designed and built for use as per below instruction. Incorrect installation, modifications, alterations and misuse of the equipment may cause serious personal harm to users and will void your motor warranty.

3. PRE-INSTALLATION CHECKS

BEFORE INSTALLATION THE INSTALLER MUST:

1. Check that the construction of the door is sound and that it will be able to tolerate potential forces resulting from overload.
2. Check that the door operates without hindrance and does not open or close as a result of its own load.
3. Tensioning and balancing of springs must be performed by a qualified person before installation of the ARC can take place.
4. Check that the door has the necessary travel stops or mechanical stops to limit the movement of the door.
5. Remove any unnecessary ropes, chains or fasteners and disable locks and latches.
6. Check that the plug used to power the ARC unit has to be a legal and safe connection that was passed by a certified electrician as part of the building CoC.
7. Check that the installation position (fixing point) of the ARC is:
 - structurally sound
 - safe (free from fire or explosion hazards)
 - adhering to the given technical specifications and limitations.

4. INSTALLATION CHECKS

DURING INSTALLATION THE INSTALLER MUST:

1. Ensure that the emergency release is not installed higher than 1.8m from the floor and ensure that instructions on the operation of the emergency release are fixed adjacent to the release mechanism.
2. Ensure that any additional keypads or control mechanisms are installed not higher than 1.5m from the floor, within sight of the moving door but at a safe distance from any moving parts.
3. Strongly recommended that safety beams be installed and operated together with the ARC unit.
4. Fix a safety warning sticker and door warning label in the immediate vicinity (and within clear view) of the door to be operated by the ARC.
5. Ensure that the working area remains clear of obstructions or obstacles.
6. Ensure an ARC counterweight is installed at the bottom end of the door. **Refer image below:**

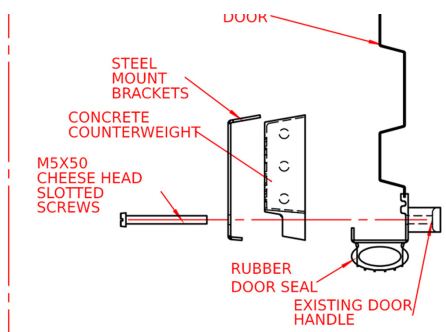

NO:	Description
1	Door Section
2	Concrete Counter Weight
3	1.6mm Pre-Galv Steel
4	Cheese Head Screws - Slotted-Plated

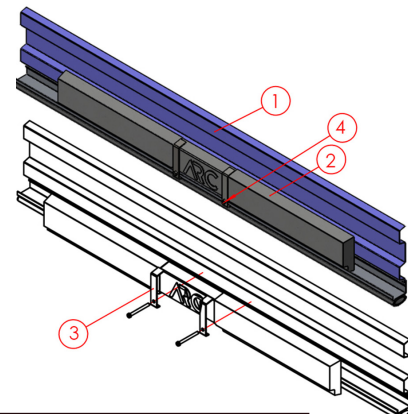

Do not attempt to run the door before Motor Orientation and Limit Switches have been confirmed

5. POST-INSTALLATION CHECKS

AFTER INSTALLATION THE INSTALLER MUST:

1. Check that designated users are properly able to operate the door controls and emergency releases.
2. Check that users are proficient in operating and testing the safety beams.
3. Provide information to designated users on checking regularly for maintenance issues that must be attended to by an installer.
4. Indicate to users that batteries may not be disposed of in general refuse disposal. Batteries must be handed to battery merchants for safe and environmentally friendly disposal.
5. Provide a copy of the user manual and safety instructions to the designated users.
6. Retain a copy of the user manual and safety instructions for their own reference purposes.

6. COMPONENTS OF THE CONTROL BOX

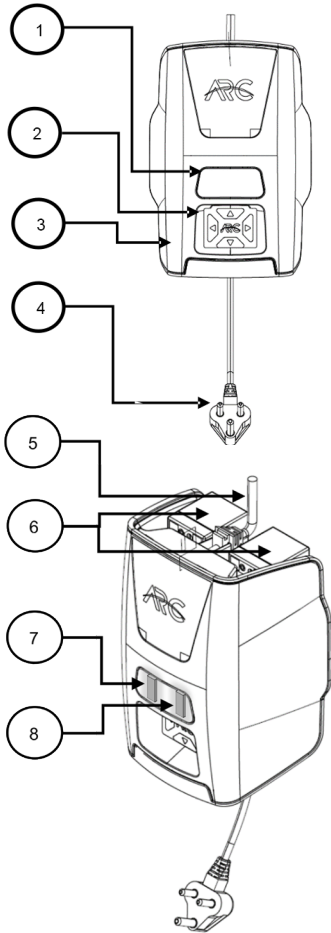

Number	Item	Description
1	Indicator lights	The unit consists of two lights: left and right indicator light
2	Touch interface	The touch interface has five buttons: centre, right, left, up and down
3	Removable cover	Remove the cover during installation to enable access to wiring
4	Standard three-pin power plug	Plug into the wall socket to power the unit
5	Motorhead connection	Wires connecting motorhead to the ARC
6	Twin batteries	Batteries serve as backup power during power failures
7	Left Indicator light	Menu
8	Right indicator light	Setting selector

7. CONTROLLER CARD AND CONNECTIONS

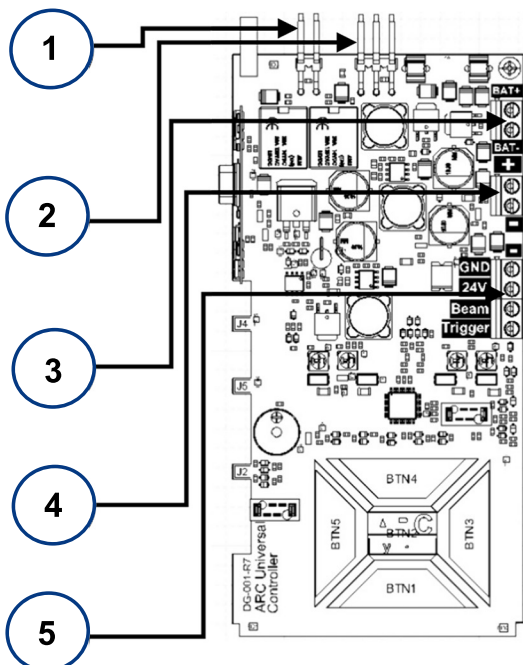

Number	Item
1	Motor connections
2	Limit switches
3	Battery connections
4	Power supply
5	Peripherals (Beams, External buttons, etc.)

8. ELECTRICAL INSTALLATION

Plug	Plug the ARC plug into the wall socket
Batteries	Place the batteries into the two slots provided, connection side up. Connect the bridging cable between the 2 batteries .

9. ARC VENITE MECHANICAL INSTALLATION

Checklist

- Door has been lubricated with a garage door lubricant (such as Blaster) and the door runs smoothly.
- Roller door curtain is properly pinned to the drum.
- Counterweight has been installed
- Ensure the door is tensioned correctly
(Quick tension test: lift or drop the door slightly and let go of the door. The door should not glide upwards or downwards)
- Set up and activate Safety beams. NB! Safety beams are recommended for safe operation.

Installation

- Mount controller to a wall (out of reach of small children)
- Remove the front cover of the control unit
- Mount the back plastics to the wall with the 4 screws supplied (See Fig. 2)
- Mount motor head to roller door
- Remove the U-Bolt of the door on the side closest to the controller
- Lift the door shaft enough to slide the motor head onto the shaft
- Fasten the U-Bolt over the motor bracket (See Fig 3)
- Set the limit switches
- Remove the limit switch cover from the motor head. (See Fig 4)
- Completely close the door and set the close limit cam. (See Fig 5)
- Completely open the door and set the open limit cam. (See Fig 5)
- Put the door in the middle position and engage the motor.
- Power the unit and connect motor cables
- Connect motor connector (2-way connector)
- Connect limit switch connector (3-way connector) (See Fig 6)
- Connect the batteries (See Fig 7)
- Connect the bridging cable between the 2 batteries (See Fig 7)
- Check all the connections
- Connect the 3-pin RSA plug to an electrical socket
- Switch on your plug to power up the system.

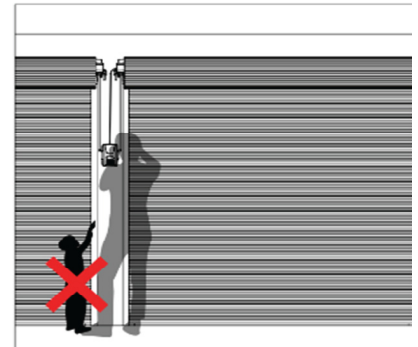

Figure 1

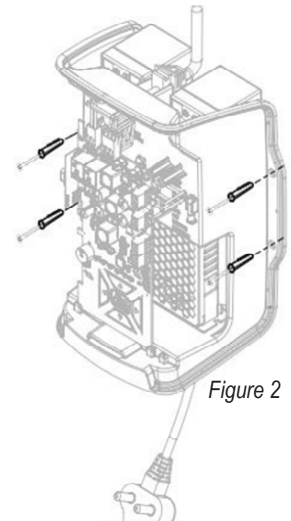

Figure 2

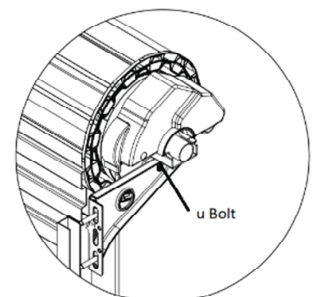

Figure 3

Programming

Verify Limit Switches (See Section 11.2)

Set Motor Orientation (See Section 10)

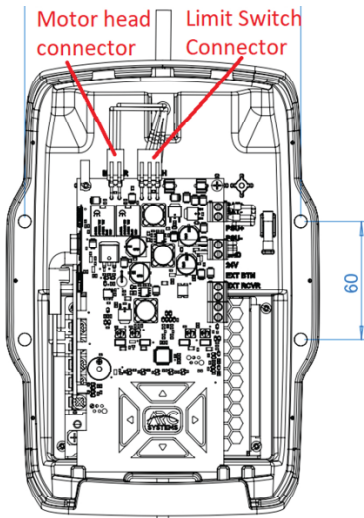

Figure 6

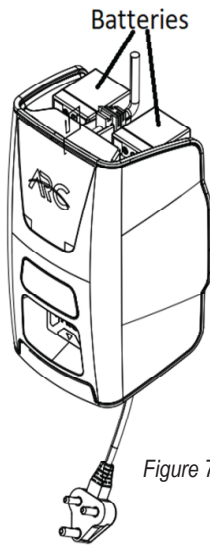

Figure 7

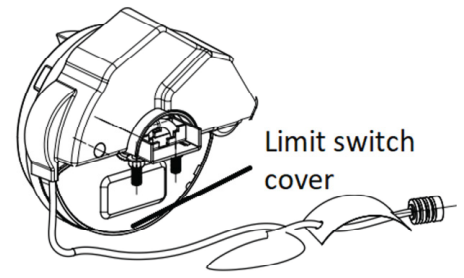

Figure 4

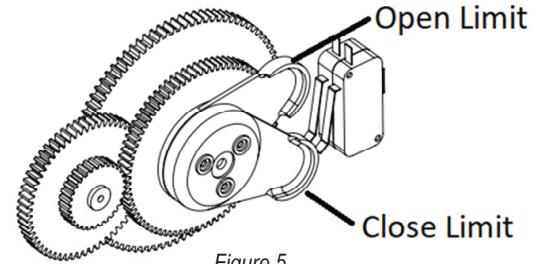
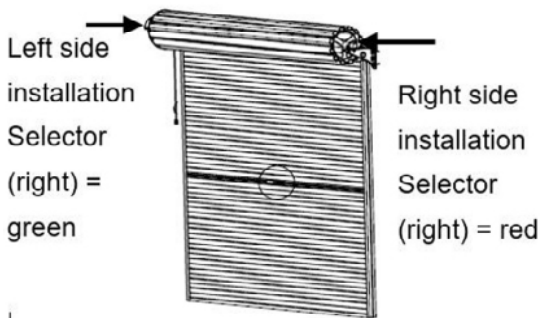
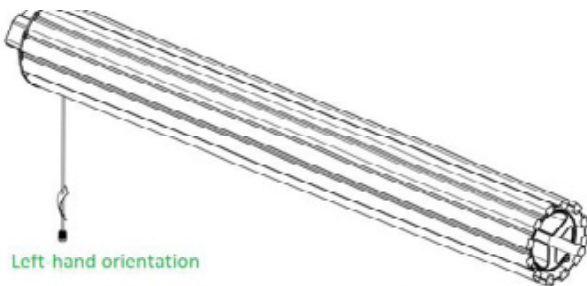

Figure 5

10. MOTOR ORIENTATION SETUP



- Enter the programming menu (Long press the centre button).
- Press the right button twice until the left-hand indicator turns yellow.
- Press the up button to find the correct motor orientation.
- Press the centre button to confirm your choice.
- Exit programming mode: Long press the centre button.



Left hand orientation

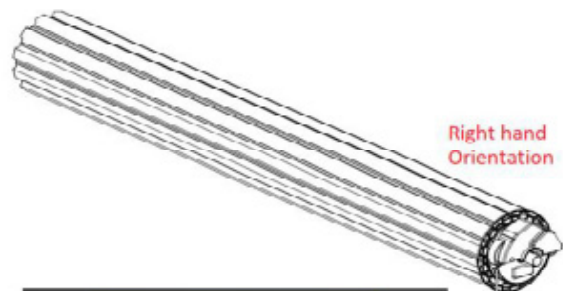

Right hand Orientation

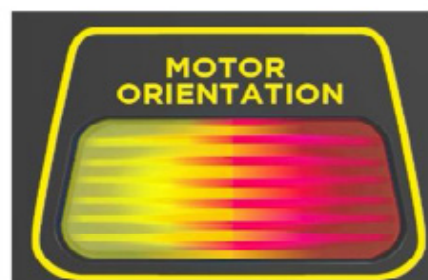
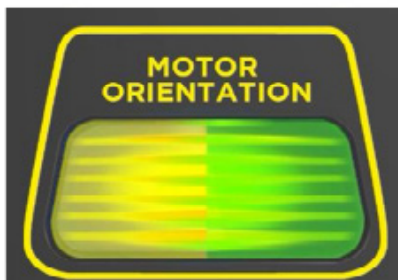

11. PROGRAMMING

11.1 Entering Programming Mode

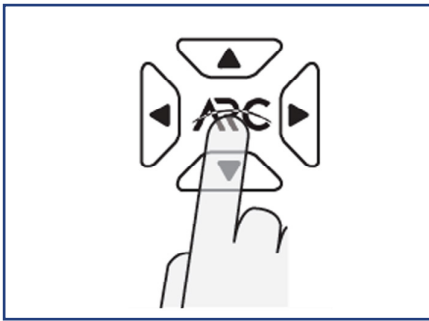

- **To enter programming mode, press and hold the centre button.**
The menu indicator (left) will turn purple indicating setup wizard.
- **To exit programming mode, press and hold the centre button.**
Both indicators will slowly turn blue.

11.2 Confirming Limit Switches

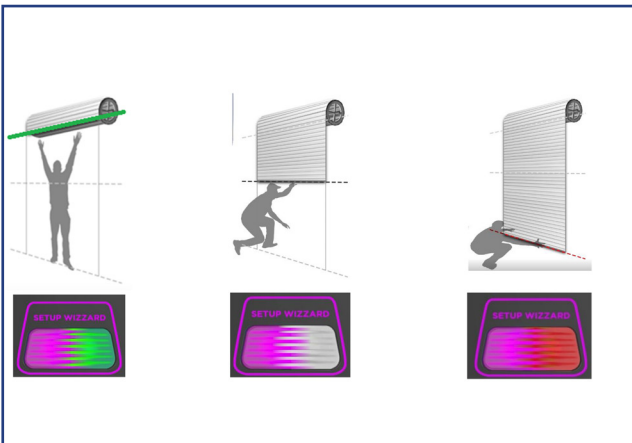

- **To verify the limit switches, enter the programming mode: press and hold the centre button.**
The menu indicator (left) will turn purple indicating setup wizard.
- **Pull the mechanical release to enable manual opening and closing of the door.**
- **Manually close the door completely.**
The setting indicator should now be red.
- **Now manually open the door completely until the selector indicator turns green.**
- **To exit programming mode, long press the centre button.**
Both indicators will slowly turn blue.

**NB! Receiving the right-hand colour confirmation is crucial during this process.
This verifies the system is aware of the door's OPEN and CLOSED positions.**

11.3 Adding Remotes

Adding non-ET BLU MIX © remotes

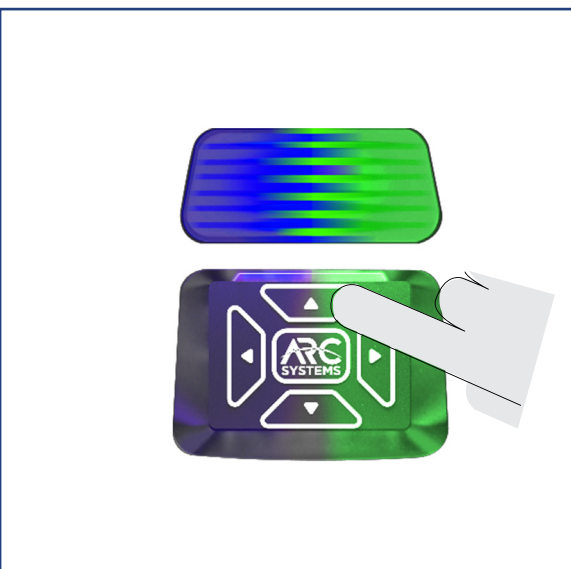

- **To Program remotes, enter programming mode and navigate to the right until the menu indicator (left) turns blue.**
- **Press and hold the UP button. The setting indicator (right) turns green.**
- **While still holding the UP button, press the remote button a second time.** The ARC will respond with a beep. This concludes the programming.
- **Press and hold centre button to exit programming mode.**
- **When pressing the remote button now, the door should open or close.**
- **If the maximum number of remote buttons allowed has been reached, the ARC sounds a double beep.**

Adding an ET BLU MIX © remote

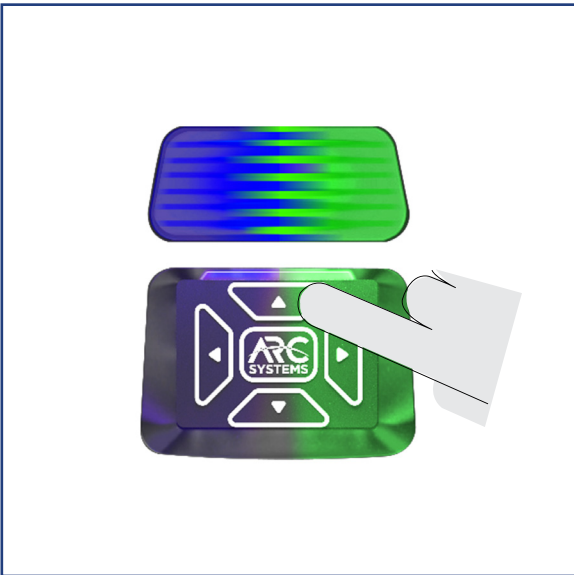

- The ARC can add/program the ET BLU Mix © to open and close the door (in the static format of the remote).
- The ET BLU Mix © has two formats in which it can transmit: Enhanced and Static format
 - ET BLU Mix © enhanced format (when the button is pressed the light on the remote shimmers)
 - ET BLU Mix © static format (when the button is pressed the light on the remote stays on)
- Set the ET BLU Mix © remote to the static format before attempting to program it into the ARC.
- To change the format: Press and hold the button for about 20 seconds until the remote light flashes distinctly off and on.

11.4 Removing remotes

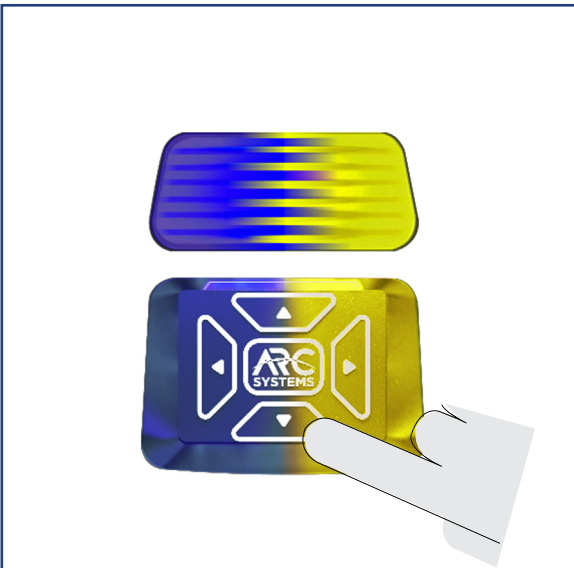

- To remove a remote, enter programming mode: press and hold the centre button.
- Navigate to the right until the system indicator (left) turns blue.
- Press and hold the down button: setting indicator (right) - turns yellow.
- While still holding the down button, select and press the previously programmed button on the remote once. This action cancels the existing programming on that remote button.
- The ARC will beep once, and the setting indicator (right) will switch off. This concludes the remote removal process.
- Exit programming mode: Long press the centre button.

11.5 Clearing all remotes



- To remove all remotes from the ARC, enter programming mode: press and hold the centre button.
- Navigate to the right until the system indicator (left) turns blue.
- Press and hold the up and down button simultaneously: setting indicator (right) - turns red.
- After the indicator turns red, press and hold the UP button to acknowledge the removal of all remotes.
- The ARC will sound a long beep and the setting indicator (right) will switch off. This concludes the clearing process.
- Exit programming mode: Long press the centre button.

12. BEAM INSTALLATION

NB! Beams cannot be activated unless they have been properly installed and are confirmed obstruction-free.

TIP: Accidental beam activation may cause conflicting system signals and unexpected responses, preventing proper use of the ARC.

- Mechanically install beams as per manufacturer specification.
- Connect beams to ARC according to the diagram shown on the right
 - 24 V = 24 Volt power connection
 - Gnd = Ground
 - COM = Common
 - NC = Normally Closed
 - NO = Normally Open
- Activate the beams.
- Activate auto close (if required).

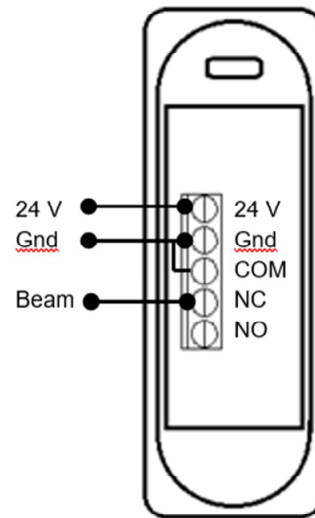

13. WARRANTY

- All manufactured goods are warranted to be free of faulty components and manufacturing defects for a period of 4 years from the date of original invoice.
- Faulty goods will be repaired or replaced free of charge at the sole discretion of the manufacturer and within the warranty period.
- This warranty is subject to the goods being returned to the premises where the goods were purchased OR shipping, handling, and packaging being paid by the customer. Verification of defect or malfunction and original proof of purchase is also required.
- This warranty is subject to the correct installation and application of goods, as laid out in the relevant documentation accompanying the goods.
- Additions to, modifications or alterations of the manufactured product will void its warranty.
- Repair or replacement costs will be for the manufacturer's account.
- Warranty claims must be accompanied by the original proof of purchase and made by the user to their respective installer.

PLEASE NOTE! The unit is battery backed-up for smaller doors but on bigger doors current is supplemented by the battery.





The following items are not covered by the warranty:

- Batteries
- Motor brushes
- Damage resultant of any weather-related instances such as lightning strikes, etc.
- Damage due to voltage dips or swells on the household mains
- Damage due to loadshedding and instability on the electrical network.
- Damage due to infestations, such as bees or ants.
- Water damage. It is the responsibility of the installer to ensure the product is fitted in a location that is protected from water ingress.
- Third-party housings do not carry any warranty with the ARC manufacturer.

14. GENERAL FAULTS AND RECOMMENDATIONS

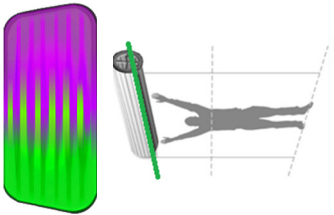
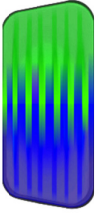
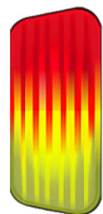
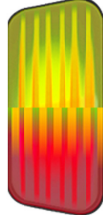
Installation	Ensure that both your door and motor installations are done by qualified persons.
Door tensioning	When tensioning a door it is advised to fully close the door, then increase the tension on the door up to the point where the door lifts about 3cm off the ground.
	A new door may require re-tensioning after the first few months of use - after the tension spring has been properly worked in and settled.
Decreasing door speed	If the speed of the door gradually starts decreasing, this may be a sign of an ageing battery. We recommend replacing the controller batteries.
Beam activation	Please take special note of instructions and tips regarding Beam Activation.
Errors and Warnings	Always heed and attend to system errors and warnings immediately.
Operation	Be sure that all users are aware of proper and safe usage practices.
Maintenance	Ensure that your ARC product is well maintained to enjoy its long-term and hassle-free usage.

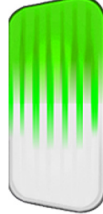
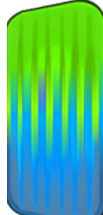
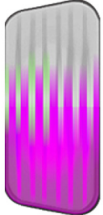
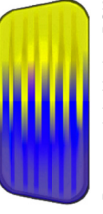
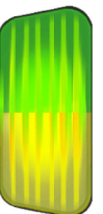
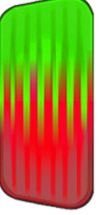
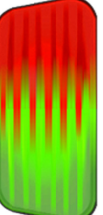
15. QUICK REFERENCE - PROGRAMMING

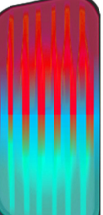
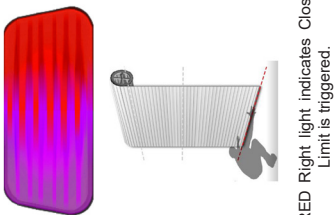
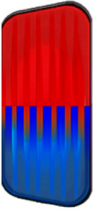







<p>Setup Wizard</p>  <p>GREEN Right light indicates Open Limit is Triggered.</p>	<p>Remote</p>  <ul style="list-style-type: none"> - Press and hold the UP button. - Right light turns GREEN. - Press the remote button that needs to be PROGRAMMED. - The controller beeps once. - Press the same remote button again - The controller gives a long beep. - Confirmation that this remote button has been successfully programmed into the system. 	<p>Motor Orientation</p>  <p>RED Right light indicates Right Hand Motor Drive Press UP/DOWN to change.</p>	<p>Closing Force</p>  <p>Right light indicates Force Used UP: increase DOWN: decrease</p>	<p>Opening Force</p>  <p>Right light indicates Force Used UP: increase DOWN: decrease</p>	<p>Beam</p>  <p>Right light indicates if Beam is activated Press UP/DOWN to change</p>	<p>Auto Close</p>  <p>Right light indicates if Auto Close is activated Press UP/DOWN to change</p>
<p>WHITE Right light indicates No Limit is triggered.</p> 	<p>Remote</p>  <ul style="list-style-type: none"> - Press and hold the DOWN button. - Right light turns YELLOW - Press the remote button that needs to be REMOVED. - The controller beeps once. - Confirmation that this remote button has been successfully removed from the system. 	<p>GREEN Right light indicates Left Hand Motor Drive Press UP/DOWN to change.</p> 	<p>Right light indicates Force Used UP: increase DOWN: decrease</p> 	<p>Right light indicates Force Used UP: increase DOWN: decrease</p> 	<p>Right light indicates if Beam is activated Press UP/DOWN to change.</p> 	<p>Right light indicates if Auto Close is activated Press UP/DOWN to change</p> 
<p>RED Right light indicates Close Limit is triggered.</p> 	<p>Remote</p>  <ul style="list-style-type: none"> - Press both UP and DOWN buttons simultaneously. - Right light turns RED. - Press and hold the UP button. - Already RED button will turn brighter RED. - Hold the button until controller beeps once. - This confirms that all remotes have been successfully removed from the system. 				<p>Beams can only be activated once they are installed and if they are not obstructed. (This is to ensure beams are not accidentally activated.)</p>	<p>Auto Close can only be triggered if Beams are activated.</p>

- **Enter or Exit** Programming Mode: long press the ARC button
- **Left and Right** arrows: navigate through Menus
- **Up and Down buttons:** change Menu settings

NB! The controller will automatically exit Programming Mode after 90 seconds of no interaction.

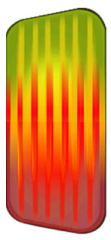
- **Single beep** indicates positive feedback.
- **Double beep** indicates negative feedback.
- **Long beep** indicates acknowledgement.

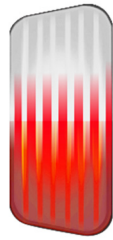
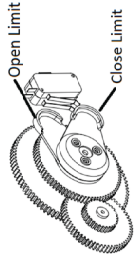
16. QUICK REFERENCE - ERRORS AND WARNINGS

Warning/Error	Image	Faults, Checks and Recommendations
Down/Close Collision		<ul style="list-style-type: none"> - Ensure the locking bar does not hook to the door rail, causing a collision sense on the controller - Any obstacles in the path of the door? - Is the door sufficiently lubricated? - Has a counterweight been installed? - Does the door travel with ease? <p>Only if all of the above is OK, increase the Closing Force of the door.</p>
Up/Open Collision		<ul style="list-style-type: none"> - Ensure the locking bar does not hook to the door rail, causing a collision sense on the controller - Any obstacles in the path of the door? - Is the door sufficiently lubricated? - Has a counterweight been installed? - Does the door travel with ease? <p>Only if all of the above is OK, increase the Closing Force of the door.</p>
Bad Batteries		<ul style="list-style-type: none"> - The batteries are starting to fail. <p>NB! It is recommended that the batteries are replaced .</p>
No Batteries		<ul style="list-style-type: none"> - There are currently no batteries installed. <p>NB! It is recommended to run the controller with batteries installed .</p> <ul style="list-style-type: none"> - Check the connectors for signs of corrosion. - Ensure bridging cable between the two batteries are connected .
No Motor Current		<ul style="list-style-type: none"> - Motor has no current. - Check cable connection to motor. - Check fuse on controller.
High Current		<ul style="list-style-type: none"> - High currents during usage of door. - Check the controller's batteries. - Double-check the door for obstacles or damage. - Lubricate the door. - If the error occurred while closing the door, a counterweight is required.
Limit Switch Error		<ul style="list-style-type: none"> - Check the orientation of the limit switch. - Check the motor orientation (Left- or Right-hand drive) 
No Power		<ul style="list-style-type: none"> - Mains power is off, and the battery voltage is too low. - Check the power supply to the unit.

WARNING = the controller flashes **YELLOW** on the left-hand indicator

NB! Even with a warning alert flashing, the controller will remain operational. But it is strongly recommended that the warning be checked and repaired as soon as possible.

ERROR = the controller flashes **RED** on the left-hand indicator

NB! An error prevents the controller from any further operation until it has been checked and repaired.

Right-hand indicator refers to the type of warning or error.

Contact one of our Branches listed Below:

Bloemfontein

051 430 0898 | bloemfontein@doorsgalore.co.za

Cape Town

021 555 0002 | cape@doorsgalore.co.za

Durban

031 700 1584 | kzn.quotes@doorsgalore.co.za

East Rand

010 443 6111 | eastrand@doorsgalore.co.za

Johannesburg

011 885 2310 | reception@doorsgalore.co.za

Midrand

081 026 2228 | midrand@doorsgalore.co.za

Nelspruit

010 443 6061 | nelspruit@doorsgalore.co.za

Polokwane

082 829 0461 | polokwane@doorsgalore.co.za

Port Elizabeth

010 443 6059 | portelizabeth@doorsgalore.co.za

Pretoria

012 804 1140 | pretoria@doorsgalore.co.za

Strijdom Park

010 443 6082 | strijdompark@doorsgalore.co.za



www.arcsys.co.za | 0860 326 666